

Hardware alarms reduction in Radio Base Stations by forecasting Power Supply Units headroom

Agustín Valencia, Oleg Gorbатов, Lackis Eleftheriadis
Ericsson Research, Sweden

{agustin.valencia, oleg.gorbatov, lackis.eleftheriadis}@ericsson.com

Abstract—Power Supply Units (PSUs) are the components that supply Radio Base Stations (RBSs) with electric power, making it an essential unit for mobile communication networks. A power supply malfunction is critical and must be resolved, but immediate troubleshooting could result in additional operational costs. Based on the prediction of PSU usage by an advanced generalized additive model for time series forecasting called Prophet, the PSU power headroom is derived and the maintenance schedule is proposed, which depends on the severity of demand for power. The safety criteria are derived from the critical operational conditions for several consecutive worst-case scenarios. A PSU alarm will only be generated under the most critical circumstances for an RBS, having multiple PSUs, and sent to the Network Operating Center (NOC). This approach not only allows us to better schedule maintenance and keep operational continuity but also to improve the overall energy efficiency and costs.

Index Terms—Power Supply Unit; Hardware Alarms; Telecommunication; Machine Learning; Time Series

I. INTRODUCTION

5G enables new use cases for industry with varying requirements and Quality of Service (QoS) [1]. Several requirements involve radio traffic and data package performance towards the User Equipment (UE), improving availability of operation of the Radio Base Station (RBS). Among many things that are overlooked in the discussion are the availability of the power infrastructure related to various use cases and the requirements related to the impact of Power Supply Unit (PSU) availability in the event of failure of one or more PSUs. Future deployment of 5G will require working stability not only for radio traffic but also for the electrical power infrastructure.

The PSU is one of the essential elements of the mobile communication network that feeds power to the radio units in the distributed access nodes. In current RBSs, in the event of a hardware fault, an alarm (or multiple alarms) is raised and triggered from the specific faulty hardware unit that is sent directly to the NOC and the Operating and Support System (OSS) in order to be processed and managed by the network service engineer. In the NOC, a request to replace the faulty unit/units is raised based on the received alarm data.

The reality is that not all of the alarms affect the radio performance or cause any direct degradation of the radio traffic, or radio performance, implying that there is no rush to dispatch

service personnel to the RBS site until its true operational continuity is threatened affecting the communication availability. Defining and planning the right time for sending field workers to the RBS to replace hardware equipment, in remote places sometimes, would positively affect the maintenance and operational costs for the mobile network operator (MNO).

Alarm reduction strategies have been the subject of extensive research recently [2], [3], [4]. The overlay signal monitoring system was proposed in [5]. This system collects various signal parameters at a subscribers site, determines if these parameters are within the allowable value range, and generates an alarm if they are not. Moreover, for alarm prioritization, an approach based on neural network has been suggested [6]. However, alarm reduction and alarm priority setting are open research problems in the field of effective alarm management and still under discussion.

Research on energy consumption in RBSs is not a new topic in the communication community and it can be seen from two different research perspectives. The first, from a modelling perspective, uses a top-down approach [7] by focusing on consumptions and, from there, describing the system. Alternatively, from a bottom-up perspective, in which the overall power consumption of the system is described by the consumption of each independent building block according to their different modes of operation [8]. The study took into account the power amplifier, analogue interface, digital baseband, digital control and power system. Both have in common that they are descriptive in nature and limit their data to pure hardware technologies and their power characteristics. Their main objective has been modelling and simulation of energy consumption in communication networks.

The second perspective uses more data than just hardware descriptions. As a result, traffic metrics have been shown to be a fundamental covariate to explain power consumption fluctuations in an RBS [9]. In [10], the Seasonal and Trend decomposition using Loess (STL) technique was applied to model the traffic load in a RBS, and then the Holt-Winter's technique [11] was used to forecast its values, so the energy management can adopt energy-saving strategies when it is not necessary to broadcast at maximum power.

When it comes to energy consumption forecasts in areas other than telecommunication, the field has also been fruitful. Sensor network's power consumption using Markov chains [12], power consumption in data centres using LASSO, elastic-net, Random Forest, KNN, and Multi-Layer Perceptron (MLP)

Submitted to the 22nd Power Systems Computation Conference (PSCC 2022).

[13], coal-mining power consumption forecast using statistic modelling [14] or laser-melting processes using linear regression [15], to name a few.

Furthermore, forecasting household electricity demand is a very fertile field itself. Linear regression, decision trees, Random Forests, Support Vector Regression (SVR) and MLP have been applied to predict the demand in northern Morocco [16] finding that Multi-Layer Perceptron (MLP) performs better than the others. Long Short-Term Memory (LSTM) networks were applied to learn household consumption and were compared to Gradient Boosting Tree and SVR approaches finding that the LSTM model, which they have called *PowerLSTM*, outperforms the others [17]. A novel Evolutionary Ensemble Neural Network Pool method has been proposed in [18] and applied to energy consumption in western Norway and this method has given better results than naive and simple predictors.

The well-known Holt-Winters model was compared against Facebook's Prophet model in long-range power loads forecast in Kuwait, reaching a Mean Absolute Percentage Error (MAPE) $\sim 2\%$ for a forecast horizon of 720 days [19]. The robustness of their predictions was tested by injecting Gaussian noise at different intensities at a fixed (unspecified) forecasting horizon, concluding that the Prophet model can make robust predictions of power demand while obtaining $R^2 \sim 0.96$ at a noise intensity of 80% [19]. Along the same lines, it was shown that the Prophet model performs better than (Autoregressive Integrated Moving Average) ARIMA models for a 30-day long range on forecasting power demand using external environmental regressors in an airport in Belgium [20]. In both studies, the weekly seasonal components of the Prophet model were used to recommend the most appropriate day of the week to perform maintenance related to power consumption.

In addition, the potential of Prophet's for long-range predictions was demonstrated by extending it to work together with a Gated Recurrent Unit (GRU) as an attention layer plus a Criteria Importance Through Inter-Criteria Correlation (CRITIC) node to weigh both predictions optimally [21]. For a prediction horizon of ~ 6 months, the proposed architecture shows MAE equals 8.5 against 10.1 and 20.1 from Prophet on its own and ARIMA, respectively. The robustness of the predictions made by Prophet models for long-range time horizons, has shown to perform better than standard methods in other fields strongly related to human behaviour. This makes it an interesting alternative to be applied in the field of communication.

This work aims to develop a machine learning method that reports an alarm if, and only if, the PSU power headroom in an RBS will reach unsafe operational levels based on the installed power capacity and power consumption forecasts. Based on state-of-the-art findings, it has been explored the Prophet's capabilities to endow the proposed solution with long-term robustness as shown in other domains. Based on the predictions, appropriate criteria for triggering alarms are

discussed to maintain operational continuity of the RBS while reducing maintenance expenditures.

II. METHODOLOGY

A. PSU Power headroom

An RBS is usually powered by redundant PSUs, as shown in Figure 1, to maintain a reliable and robust operational condition in the event of single or multiple faults. Despite the power redundancy, an alarm is sent from the PSUs even if there is no need for an immediate replacement of the faulty PSU hardware, since the RBS still has enough power available from the other PSUs and distributed via the Power Distribution Unit (PDU) to continue its operation without risk of total failure. To the excess power given by the redundant PSU is added the fact that the total power capacity is not used all the time because the radio traffic has a clear seasonal component and the radio units (RUs) do not continuously transmit at their maximum capacity.

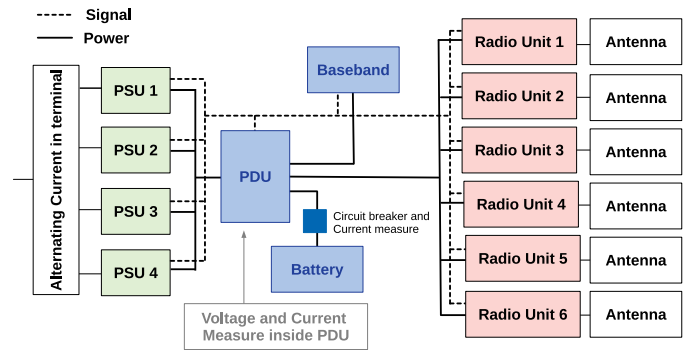

Fig. 1: Example of a power infrastructure in an RBS

Given this surplus in energy, the PSU power headroom (P_h) can be defined as the difference between the electrical power consumption P_{cons} and the maximum available power P_{max} :

$$P_h = P_{max} - P_{cons}, \quad (1)$$

where P_{cons} is the consumed power seen from the PSU, which will include the RU power consumption, the static power consumption, the consumption of the cooling system, the losses in the lines, among others.

B. Hardware alarm strategy

Current systems usually report two levels of incidents to the NOC in a binary fashion, i.e., alarm on/off. Minor alarms do not imply a direct operational continuity threat whereas major alarms do, and as a consequence they generate a repair request to the system operators. In the following section, we propose a criterion that allows us to lower the level of individual PSU hardware faults to minor alarms, and let the RBS, as a system, decide to raise a major alarm only when the operational continuity is foreseen to reach unsafe levels and, attached to it, an indication of the available PSU power headroom to notify the NOC how stretch is the operational state¹.

¹Patent for indications apparatus under process to be public

Figure 2 shows in yellow how the power availability shrinks as a consequence of PSU hardware failures, depicted by orange events. In this example, the system is set to have an allowed minimum power headroom of 2 kW. The power demand is shown in purple and the power headroom in green, as its complement. It can be seen that the power headroom only reaches its critical level after two PSU faults. When these analyses are performed over forecasts, it enables the proposed criterion.

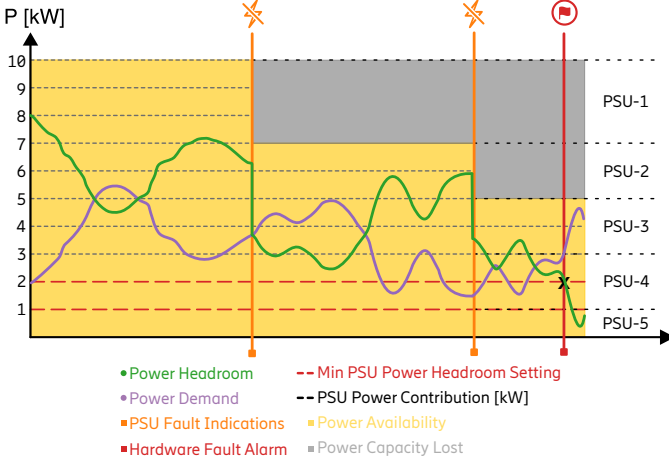

Fig. 2: PSU Power headroom decreasing as a consequence of hardware faults.

A PSU does not partially fail, this means that their power contribution is not a continuous and, therefore, the power availability has a discrete domain. In order to set a robust alarm trigger criterion, it has been asked the following question: "can the RBS still work if the next failure is the PSU that makes the largest power contribution?". This question, although depicts a low probability event, defines the worst-case scenario; therefore, it covers all other scenarios.

Let P_{max} be the maximum power capacity installed and working in an RBS, \bar{P}_{Load} is the average PSU utilization, and Δp is the confidence interval of the utilization estimation. Let N be the amount of working PSUs, and define the list $\{P_{PSU_1}, \dots, P_{PSU_N}\}$ such that $P_{PSU_1} > \dots > P_{PSU_N}$ are the descending sorted power contributions from the working PSUs.

Then, extending the worst-case scenario to a succession of n worst possible failures, the operators can set a flexible operational margin as:

$$P_{max} - \sum_{i=1}^n P_{PSU_i} > \bar{P}_{Load} + \Delta p \quad (2)$$

However, as the PSU power headroom is by definition the difference between the installed power capacity and the power being consumed, it can be said that:

$$\begin{aligned} P_h &= P_{max} - (\bar{P}_{Load} + \Delta p) \\ P_h &> \sum_{i=1}^n P_{PSU_i} \end{aligned} \quad (3)$$

where $P_{crit_n} = \sum_{i=1}^n P_{PSU_i}$ defines the n -level criterion threshold. Thus, given an application-defined parameter n , it is proposed a criterion that will trigger an alarm only when the system will not be able to support n successive worst-case scenario failures.

C. Machine learning models

A time series has a seasonality of period s if $Y_t = Y_{t-s}$. Written using the time-series backshift operator, this is $Y_t = B^s Y_t$. It can be said that a random process $\{Y_t\}$ follows a Seasonal ARIMA (SARIMA) model with period s if and only if the sequence $\{X_t\}$ in Eq. (4) is a causal ARMA process defined by Eq. (5) [22].

$$\{X_t\} = (1 - B)^d (1 - B^s)^D \{Y_t\} \quad (4)$$

$$\phi(B)\Phi(B^s)X_t = \theta(B)\Theta(B^s)Z_t, \quad \{Z_t\} \sim \mathcal{N}(0, \sigma^2). \quad (5)$$

Using backshift properties, Eq. (5) can be rewritten as:

$$\phi(B)\Phi(B^s)(1 - B)^d (1 - B^s)^D \{Y_t\} = \theta(B)\Theta(B^s)Z_t, \quad \{Z_t\} \sim \mathcal{N}(0, \sigma^2), \quad (6)$$

where p, d and q refer to the autoregressive, integral and moving-average parameters of the ARIMA model, respectively. P, D and Q are the autoregressive, integral and moving-average parameters of the seasonal construction for the period s . It should be noted that properly tuning ARIMA models is not a simple process. Nonetheless, in [23], a heuristic based on greedy algorithms and statistical tests was proposed to approximate reasonable models. This work is based on its implementation on the AutoARIMA library for R [24].

The Prophet model is a statistical model developed by Facebook and has been open-sourced and provides Application Programmable Interface (API) for Python and R languages [25]. The Prophet's core has been implemented in Stan [26], which uses Markov Chain Monte Carlo (MCMC) algorithms to sample from the defined models: Hamiltonian Monte Carlo (HMC) [27] and its adaptive variation no-U-turn sampler (NUTS) [28]. The model takes a regression-fitting approach to learn the time series and then forecasts by extrapolating such models and adding uncertainty in a Bayesian framework.

The Prophet model uses a decomposable time series model [29] with three main components: trend, seasonality and holidays:

$$y(t) = g(t) + s(t) + h(t) + \varepsilon_t, \quad (7)$$

where $g(t)$ is a trend function that models non-periodic fluctuations, $s(t)$ captures different kinds of seasonalities, $h(t)$ represents special situations that could add irregularities to the other components (holidays) and a random error term ε . The model is built as a Generalized Additive Model (GAM) [30], which allows more and more components to be added as needed.

By using the GAM flexibility, it is possible to add different seasonality periods, said daily, weekly and monthly seasonalities. These seasonalities are modelled by the use of Fourier series and estimated by an exponential smoothing approach

[31]. For every given period P_i , the seasonal component s_i can be defined as:

$$s_i(t) = \sum_{n=1}^N \left(a_n \cos \left(\frac{2\pi n t}{P_i} \right) + b_n \sin \left(\frac{2\pi n t}{P_i} \right) \right), \quad (8)$$

which has $2N$ parameters to learn.

The flexibility of GAMs also allows the inclusion of *external regressors* to help fit the model. They can be included in two different modes: as an additive component $a(t)$ or as a multiplicative factor of the trend model $m(t)$. Each is scaled by a corresponding factor χ_a and χ_m , respectively². The general multivariate model, including A additive external regressors and M multiplicative external regressors, is expressed as:

$$y(t) = g(t) \left\{ 1 + \sum_{i=1}^M \chi_{m_i} m_i(t) \right\} + \sum_{i=1}^A \chi_{a_i} a_i(t) + \sum_i s_i(t) + \sum_i h_i(t) + \varepsilon_t \quad (9)$$

where $\{\chi_{a_i}, \chi_{m_i}\} \in b \cdot B_i$, $B_i \sim \text{iid } \mathcal{N}(0, 1)$. $b \in \mathbb{R}$, $b > 0$ and b can be used as a regularization factor. The random parameters are then learnt by maximum a posteriori estimation using Stan's built-in L-BFGS-B optimizer.

Although it is possible to include external regressors in Prophet models as multivariate inputs to improve its accuracy, it still is a univariate predictive model. This implies that for forecasting tasks, the future values of the external regressors must be known. For the present work, the multivariate Prophet model has been extended by embedding a collection of univariate Prophet models for the defined external features. Each of them only predicts the future values of an external feature, and later, those predictions are used as external inputs for predicting the target variable in the multivariate Prophet model as shown in Figure 3.

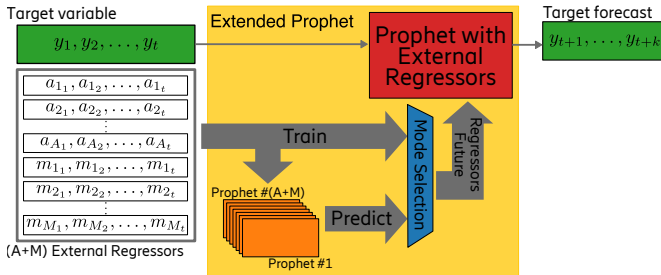

Fig. 3: Extended Prophet model architecture

D. Data description and implemented framework

The data available is in the form of time series indexed by an RBS unique identifier and the time stamp corresponding to sample time. The data is sparse and in different files depending on the domains from which the features were measured, i.e.,

²This model formulation is not part of the original publication, but it has been deduced from the open sourced code implementation. Therefore, the presented nomenclature cannot be considered *standard*, as the model's authors do not explicitly use it

the power supply, power distribution, radio traffic, climate etc. After merging data from the different domains by the time stamps, structural time series models in state-space domain have been approximated by applying maximum likelihood estimation with L-BFGS-B optimization and used to impute the missing data by applying the Kalman smoothing algorithm [22], [32], [33].

PSU utilization refers to the percentage of PSU's power capacity being consumed by the loads over a determined time. These statistics are, in fact, the most crucial feature in the present work. As there are no direct PSU power headroom measurements, the PSU utilization is chosen as the target variable. Moreover, in this work, radio traffic and climate related features have also been included³. such as the established connections, the physical resource blocks (PRB) in the uplink (UL) and downlink (DL) directions, the active users connected to the UL and DL directions, the consumed radio cells energy, and the cabinet temperature. It should be noted that in the data, it is possible to observe the highly seasonal characteristics of users' behavior influenced by the day-night cycle.

By joining all the described parts, the resulting pipeline is shown in Figure 4. The obtained results are summarized in the following sections.

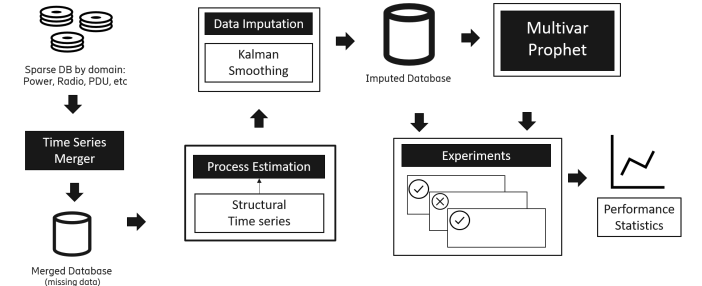

Fig. 4: Overall pipeline architecture

III. RESULTS AND DISCUSSION

A. PSU load prediction

As mentioned, the Prophet model has been chosen for PSU load prediction due to its flexibility and shown good performance in long-range forecasts in other domains. As baseline measurements, it has been used the Kalman filtering prediction on models obtained by the Auto-ARIMA algorithm with seasonality detection enabled and the structural time series models obtained in the data imputation process [22].

Experiments for testing the baseline and Prophet models consist of iterative evaluations in terms of the root-mean-square error (RMSE) metric of the predictions while the predicting horizon moves further and further, i.e., the forecasted window increases its length. Figure 5 shows the aggregated

³Due to data usage legal restrictions and customers' privacy, internal identifiers used by the company's operations and dates in all timestamps have been anonymized in the paper. Moreover, the data structures and sensitive data values have not been presented

performance for all the test models for a maximum horizon of 5 days. The aggregated performance has been calculated as an average of RMSE metrics for 20 randomly selected RBSs.

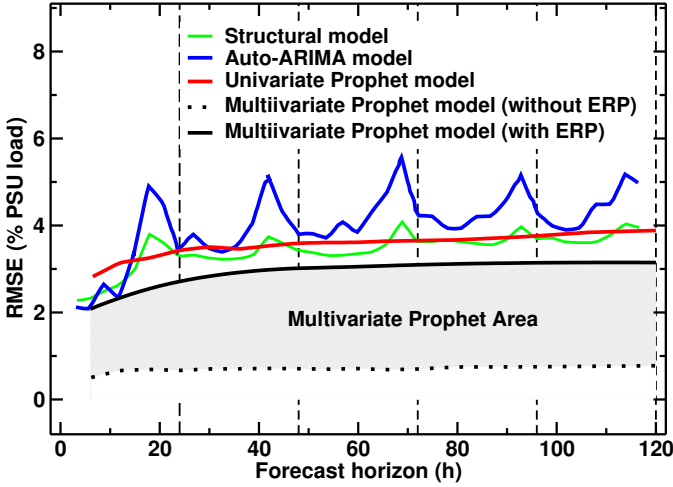

Fig. 5: RMSE for baseline and Prophet models as a function of the forecast horizon time. The dependence of predictions by the multivariate Prophet model on the external regressors is represented by a grey color area that is restricted by the predictions with and without the external regressors prediction (ERP).

As in any forecasting application, the further in the future, the higher the inaccuracies, which for all the models do not exceed 5.8% of the PSU utilization. The predictions by the baseline models present an interesting seasonal shape in the errors. As they occur during the night hours, their explanation is related to the difference of variability between the minima and maxima, i.e., predicting the maxima is a more error-prone task since the power consumed during the day varies more than in the night hours, thus predicting the minima produce less errors since their value varies the less. The fact that the errors produced by the Prophet models do not present the same seasonal pattern than the baselines, shows that the seasonalities in the PSU utilization are being well approximated by the models.

Figure 5 presents results for the multivariate Prophet model with and without the external regressors prediction (ERP). The latter uses the known true values of the external regressors, thus the multivariate Prophet model without ERP shows the best possible prediction limit. These two PSU load lines predicted by the multivariate Prophet models form an area that shows the multivariate Prophet prediction depending on the external regressors. Therefore, the accuracy improvement for external regressors predictors allows us to essentially improve the prediction of the PSU load into ranges lower than 1% RMSE and shows that it is worthy to further research towards that direction.

The Prophet model using external regressors shows the best performance. In the long-range, the univariate Prophet model shows RMSE about 3.8% PSU utilization, while the

multivariate Prophet model shows RMSE about 3.1%. When it comes to comparing the baselines performances against the univariate Prophet model, it can be seen that the latter sometimes performs even worse than the baselines, which might induce some critical thoughts about the Prophet model as an insufficient framework. Nonetheless, when adding exogenous regressors, the model shows its potential by lowering the error rates significantly. Thus, the Prophet model with exogenous regressors outperforms the other considered methods. In addition, the long-range stability of the multivariate Prophet model is observed, having the best RMSE score.

B. PSU power headroom and alarm reduction

In general terms, an alarm is meant to indicate to someone that something abnormal is happening in a given process or, in a forecasting context, may (or will) occur in the future, to support the operator response [34]. In the context of the present work, the alarm definition meaning can be conceived as the RBS not having enough power to maintain its by-design behavior.

Although it is possible to define in probability terms how likely a power overload may be given the system current state, as any Markovian process, triggering an alarm is always a binary problem. The system is running either in a *safe* or in an *abnormal* operating region, and then, crossing the boundary that separates these two regions is the alarm triggering criterion.

There are many different techniques to tune an optimal trigger level. It could be done based on a system variable, or latent variable, or even a joint distribution of the two types [35]. The choice of the best possible boundary has been left for future research. As an initial approach, it has been proposed to be configurable by the user according to their needs and expertise through the exposition of the n parameter in our criteria.

There is no direct measurement available for the PSU power headroom. Nonetheless, as defined in Eq. (1), it can be obtained from the consumption seen from the PSU, as it is conceptually its complement. Thus, forecasting the PSU utilization is still a useful procedure for predicting the PSU power headroom.

Let $P_{L[\%]}$ be a measure of how many percentual capacity of the installed power P_{max} is used at a given time, which is an available measure. Then, the percentual PSU power headroom $P_{h[\%]}$ is defined in Eq. (10). If the interest is to obtain a measurement in Watts, the installed power capacity in the RBS $P_{max[W]}$ needs to be known.

$$P_{h[\%]} = 100 - P_{L[\%]}$$

$$P_{h[W]} = P_{max} \left(1 - \frac{P_{L[\%]}}{100} \right) \quad (10)$$

Figure 6 shows an example of a PSU power headroom signal and the discrete levels of the contributions of each of the installed PSU in a given RBS. Considering that the power reductions are not continuous but quantized, the PSU power headroom cannot be less than the most significant PSU

power contribution as shown in Figure 6. Furthermore, this conclusion has been extended for n consecutive worst-case scenarios, and the n -level safety criteria has been proposed.

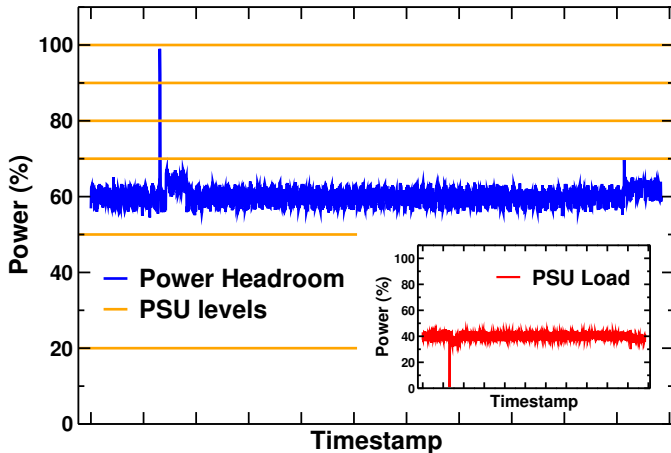

Fig. 6: PSU power headroom and discrete availability. In the insert, the PSU load is shown.

Based on the n -level criteria from Eq. (3) whenever the PSU power headroom forecast \hat{P}_h at time $t + k$, where t is the current time and k is the amount of samples in the future, meets the condition:

$$\hat{P}_{h_{t+k}} \geq P_{crit_n}, \quad (11)$$

a fault alarm must be triggered and sent to the NOC.

Although the n -level criteria framework allows to set a reasonable threshold to trigger the alarm only when it is needed and decrease the amount of alarms, it still relies on an expert to tune its value. In order to fully automate the new predictive alarm system, it is also necessary to apply an optimization technique to find the best alarm criterion which has been left for further research.

Thus, this paper opens a line of research towards reducing the operational costs of MNOs. Using this approach will be also beneficial for the field personnel, whose maintenance duties can imply some risks to the field workforce when, for instance, the RBS is located in a remote location. Moreover, from an environmental standpoint, reducing the number of trips and interventions in remote locations, which could be close to nature wildlife, will also reduce related pollution levels and invasions of wildlife. It should be noted that the reduction in MNO costs will be achieved without taking into account the logistics in maintenance, nor constraints of stock of replacement equipment or the geographical location of RBSs.

IV. CONCLUSIONS

PSUs are the components that supply with electrical power to the RBS, and is one of the essential elements of mobile communication networks. The power consumption is translated into PSU power headroom terms based on the PSU load utilization prediction. Considering that the power reductions are not continuous but quantized, a new initial alarm criterion

is set. The n -level safety criterion is derived from the critical operational conditions' definition of the PSU power headroom for several consecutive worst-case scenarios. It is proposed that lowering the criticality of PSU failures from alarms to indications, and running these criteria in a loop for the real time and forecasted power needs and power availability, enables an overall reduction of hardware alarms in RBSs, and as a result, improves the operational costs for the MNOs.

Methods such time series techniques have been applied to estimate the process models and to impute the missing data. Moreover, these models have also been used to forecast the future samples to define the baseline performance model. The baseline models, auto-ARIMA and structural time series, show reliable results but only for short-range time prediction. The future load power consumption has been predicted using Prophet, a state-of-the-art generalized additive model developed to forecast time series. This model shows good results not only for the short-range time prediction but also for the long-range one. Our results show that the Prophet model outperforms the considered baselines for long-range forecasts, which is particularly important for working with hardware maintenance. Thus, an algorithm for computing the real-time PSU power headroom has been proposed. This approach allows us not only to schedule hardware maintenance but also to improve energy efficiency.

REFERENCES

- [1] X. Lin and N. Lee, *5G and Beyond: Fundamentals and Standards*. Springer Nature, 2021.
- [2] P. Goel, A. Datta, and M. S. Mannan, "Industrial alarm systems: Challenges and opportunities," *Journal of Loss Prevention in the Process Industries*, vol. 50, pp. 23–36, 2017.
- [3] P. Goel, E. Pistikopoulos, M. Mannan, and A. Datta, "A data-driven alarm and event management framework," *Journal of Loss Prevention in the Process Industries*, vol. 62, p. 103959, 2019.
- [4] J. Wang, F. Yang, T. Chen, and S. L. Shah, "An overview of industrial alarm systems: Main causes for alarm overloading, research status, and open problems," *IEEE Transactions on Automation Science and Engineering*, vol. 13, no. 2, pp. 1045–1061, 2015.
- [5] S. Wallin, "Alarm and service monitoring of large scale multi-service mobile networks," Ph.D. dissertation, Luleå tekniska universitet, 2009.
- [6] J. Vucetic and P. Kline, "Signal monitoring system for wireless network operation and management," in *ITS'98 Proceedings. SBT/IEEE International Telecommunications Symposium (Cat. No. 98EX202)*. IEEE, 1998, pp. 296–300.
- [7] O. Arnold, F. Richter, G. Fettweis, and O. Blume, "Power consumption modeling of different base station types in heterogeneous cellular networks," in *2010 Future Network & Mobile Summit*. IEEE, 2010, pp. 1–8.
- [8] B. Debaillie, C. Desset, and F. Louagie, "A flexible and future-proof power model for cellular base stations," in *2015 IEEE 81st Vehicular Technology Conference (VTC Spring)*. IEEE, 2015, pp. 1–7.
- [9] A. Mourato, D. Duarte, I. Pinto, and P. Vieira, "A novel and realistic power consumption model for multi-technology radio networks," *URSI Radio Science Bulletin*, vol. 2018, no. 364, pp. 20–29, 2018.
- [10] P. Piunti, S. Morosi, and E. Del Re, "Traffic forecast and power consumption management in cellular networks," *Traffic*, vol. 40, no. 60, p. 80.
- [11] P. R. Winters, "Forecasting sales by exponentially weighted moving averages," *Management science*, vol. 6, no. 3, pp. 324–342, 1960.
- [12] M. Achir and L. Ouvry, "Power consumption prediction in wireless sensor networks," in *Proceedings of the 16th ITC Specialist Seminar on Performance Evaluation of Wireless and Mobile Systems*. Citeseer, 2004.

- [13] T. Deepika and P. Prakash, "Power consumption prediction in cloud data center using machine learning," *Int J Electr Comput Eng (IJECE)*, vol. 10, no. 2, pp. 1524–1532, 2020.
- [14] D. Antonenkov and D. Solovev, "Mathematic simulation of mining companys power demand forecast (by example of neryungri coal strip mine)," in *IOP Conference Series: Earth and Environmental Science*, vol. 87, no. 3. IOP Publishing, 2017, p. 032003.
- [15] J. Lv, T. Peng, Y. Zhang, and Y. Wang, "A novel method to forecast energy consumption of selective laser melting processes," *International Journal of Production Research*, pp. 1–17, 2020.
- [16] A. Salam and A. E. Hibaoui, "Comparison of machine learning algorithms for the power consumption prediction: Case study of Tetouan city," in *2018 6th International Renewable and Sustainable Energy Conference (IRSEC)*, 2018, pp. 1–5.
- [17] Y. Cheng, C. Xu, D. Mashima, V. L. Thing, and Y. Wu, "Powerlstm: power demand forecasting using long short-term memory neural network," in *International Conference on Advanced Data Mining and Applications*. Springer, 2017, pp. 727–740.
- [18] S. Ai, A. Chakravorty, and C. Rong, "Household power demand prediction using evolutionary ensemble neural network pool with multiple network structures," *Sensors*, vol. 19, no. 3, p. 721, 2019.
- [19] A. I. Almazroue, A. M. Almeshal, A. S. Almutairi, M. R. Alenezi, and S. N. Alhajeri, "Long-term forecasting of electrical loads in Kuwait using Prophet and Holt-Winters models," *Applied Sciences*, vol. 10, no. 16, p. 5627, 2020.
- [20] R. Chadalavada, S. Raghavendra, and V. Rekha, "Electricity requirement prediction using time series and Facebooks PROPHET," *Indian Journal of Science and Technology*, vol. 13, no. 47, pp. 4631–4645, 2020.
- [21] Y. jiang Li, Y. Yang, K. Zhu, and J. Zhang, "Clothing sale forecasting by a composite gru-prophet model with an attention mechanism," *IEEE Transactions on Industrial Informatics*, 2021.
- [22] P. J. Brockwell, P. J. Brockwell, R. A. Davis, and R. A. Davis, *Introduction to time series and forecasting*. Springer, 2016.
- [23] R. J. Hyndman and Y. Khandakar, "Automatic time series forecasting: The forecast package for R," *Journal of Statistical Software, Articles*, vol. 27, no. 3, pp. 1–22, 2008. [Online]. Available: <https://www.jstatsoft.org/v027/i03>
- [24] S. Moritz and T. Bartz-Beielstein, "imputeTS: Time Series Missing Value Imputation in R," *The R Journal*, vol. 9, no. 1, pp. 207–218, 2017.
- [25] S. J. Taylor and B. Letham, "Forecasting at Scale," *The American Statistician*, vol. 72, no. 1, pp. 37–45, 2018.
- [26] B. Carpenter, A. Gelman, M. D. Hoffman, D. Lee, B. Goodrich, M. Betancourt, M. A. Brubaker, J. Guo, P. Li, and A. Riddell, "Stan: a probabilistic programming language." *Journal of statistical software*, vol. 76, no. 1, pp. 1–32, 2017.
- [27] M. Betancourt, "A conceptual introduction to Hamiltonian Monte Carlo," *arXiv preprint arXiv:1701.02434*, 2017.
- [28] M. D. Hoffman and A. Gelman, "The No-U-Turn sampler: adaptively setting path lengths in Hamiltonian Monte Carlo." *J. Mach. Learn. Res.*, vol. 15, no. 1, pp. 1593–1623, 2014.
- [29] A. C. Harvey and S. Peters, "Estimation procedures for structural time series models," *Journal of forecasting*, vol. 9, no. 2, pp. 89–108, 1990.
- [30] T. Hastie and R. Tibshirani, "Generalized additive models: Some applications," *Journal of the American Statistical Association*, vol. 82, no. 398, pp. 371–386, 1987.
- [31] E. S. Gardner Jr, "Exponential smoothing: The state of the art," *Journal of forecasting*, vol. 4, no. 1, pp. 1–28, 1985.
- [32] S. Moritz, A. Sardá, T. Bartz-Beielstein, M. Zaefferer, and J. Stork, "Comparison of different methods for Univariate Time Series Imputation in R," *arXiv e-prints*, p. arXiv:1510.03924, Oct. 2015.
- [33] J. Durbin and S. J. Koopman, *Time series analysis by state space methods*. OUP Oxford, 2012, vol. 38.
- [34] ANSI/ISA, "Management of alarm systems for the process industries," 2016.
- [35] I. Izadi, S. L. Shah, D. S. Shook, and T. Chen, "An introduction to alarm analysis and design," *IFAC Proceedings Volumes*, vol. 42, no. 8, pp. 645–650, 2009.